

### PARTS LIST:

- |  |                            |
|--|----------------------------|
| 1 Main Base                              | 1 1/4-20 x 1 3/4 Hex Bolt  |
| 1 Upright                                | 6 5/16 Washers             |
| 1 Support Bar                            | 3 5/16-18 Hex Nuts         |
| 1 Bottle Holder                          | 3 5/16-18 x 1 Hex Bolts    |
| 22 1/4 Washers                           | 6 3/16 x 1 x 1 Rubber Feet |
| 12 1/4-20 Hex Nuts                       |                            |
| 4 1/4-20 x 1 1/2 Pan Head Machine Screws |                            |
| 5 1/4-20 x 1 Round Head Machine Screws   |                            |



### Stand Assembly Instructions:

1. Attach the Upright to the Main Base. The runners on the Main Base may need to spread out to allow the Upright to drop into place while aligning the bolt holes.
2. Attach the Support Bar. Attach to floor base with bolt coming up through the bottom of bracket.
3. Place adhesive backed Rubber Feet evenly spaced on the bottom of the rails and Main Base.

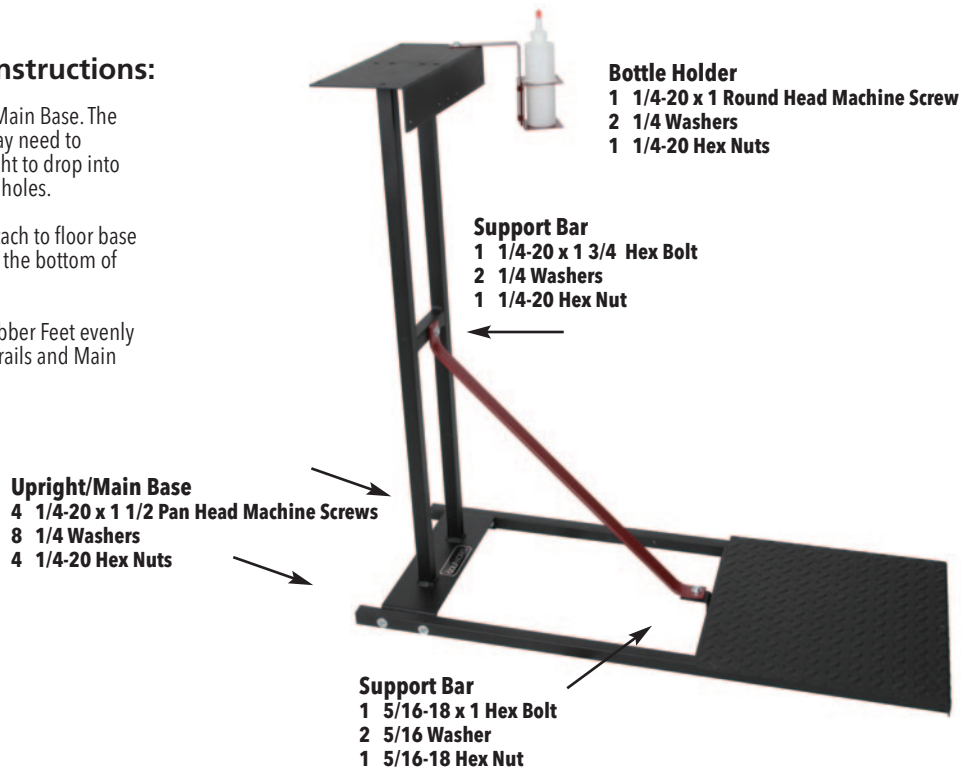

### Attaching GolfWorks Gripping Station (GGS):

1. Fully assemble GGS per instructions provided with the unit prior to attaching to the Micro Gripping Station Stand.

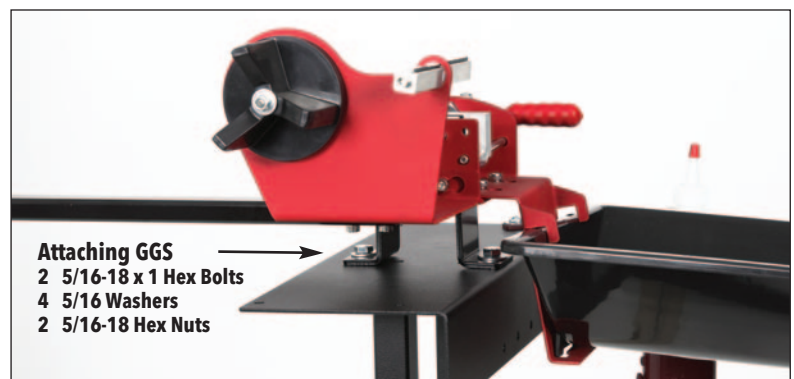

## Attaching Optional Golfworks Gripping Tools:

Pro Lever Action Shaft Holder (PASH)  
GolfWorks Grip Tape Dispensers (GW1100 or SX2TD)

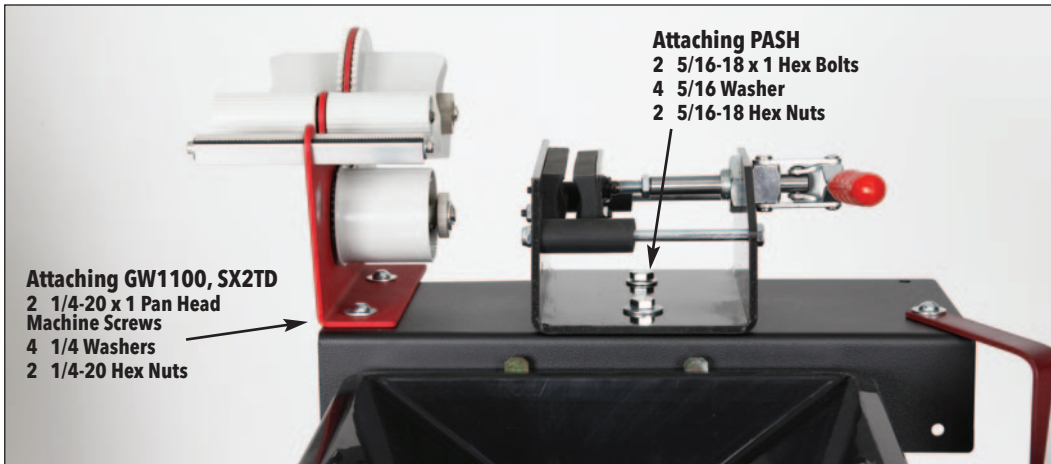

GolfWorks Speed Clamp (GW0111)

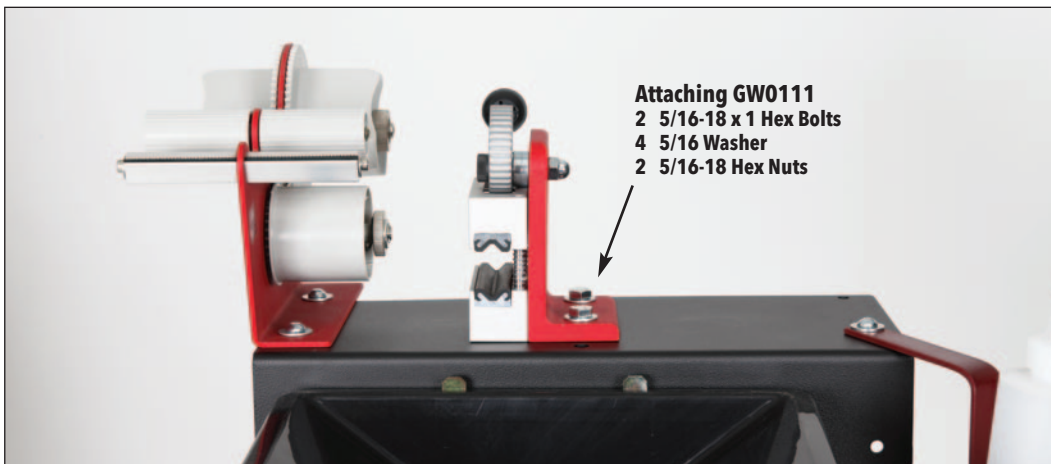

Solvent Catch Basin (UCMVGP)



## TOP PLATE HOLE DIAGRAM

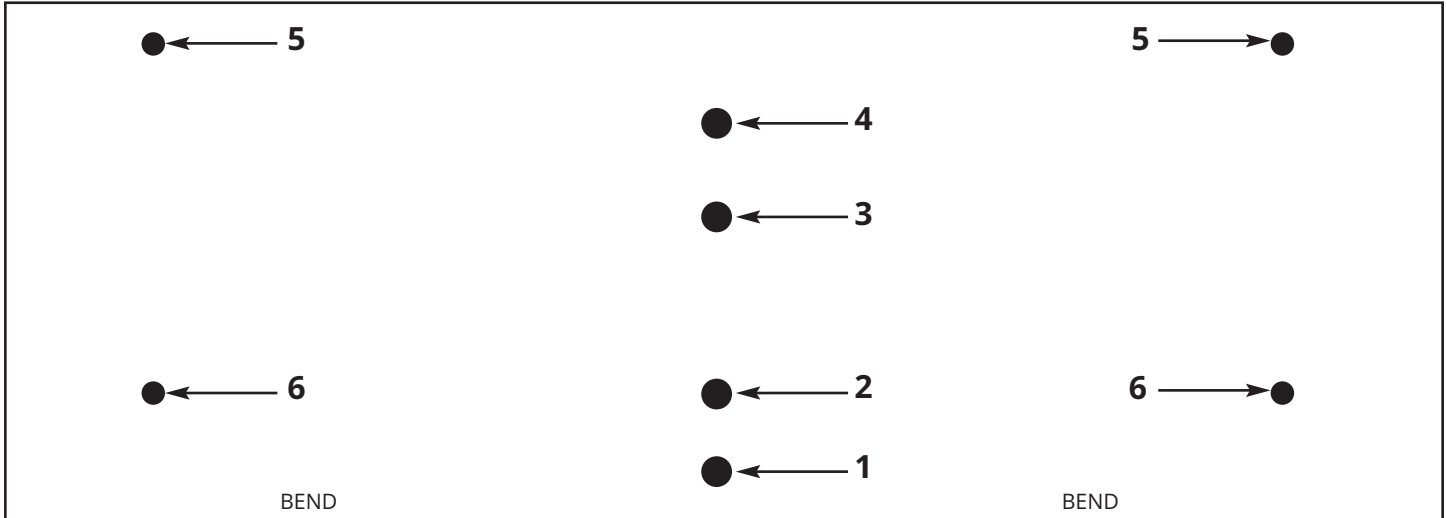

<b>Mounting on TOP PLATE see chart below</b>
<b>GGs = #1 and #4</b>
<b>PASH = #2 and #4</b>
<b>GW0111 = #2 and #3</b>
<b>SX2TD = #5 and #6 (RH &amp; LH OPTION)</b>
<b>BOTTLE HOLDER = #6 (OPPOSITE OF TAPE DISPENSER)</b>

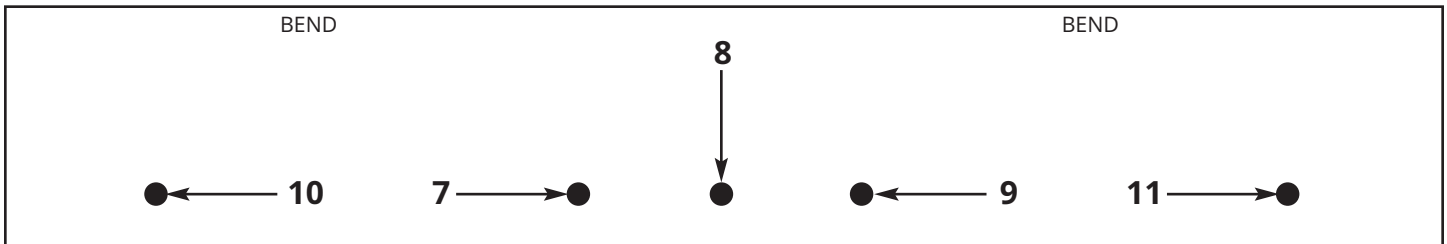

### Mounting on FRONT PLATE see below

**UCMVGP = #7, #8, #9 (RH & LH OPTION)**  
**EXTRA HOLS FOR CUTOMERS USE**